

# **DuraBlue EZ-Fit Wheel Spacers**

## ***Must read Installation Instructions!***



Congratulations on your purchase of the original DuraBlue EZ-Fit wheel spacers. Please take a moment to follow these simple instructions to get the maximum benefit from your EZ-Fit wheel spacers. Your kit comes complete and ready to install!

1. Jack up your ATV, remove the lug nuts and then the tire.
2. Screw the stud extenders onto your existing wheel studs, making sure the stud extender is screwed all the way down. **Tighten the stud extender a little better than hand tight.** Do not tighten with a pipe wrench as you could crack the stud extender!
3. Place your spacer over the studs so it sits all the way down on your wheel hub. You may have to align your lug bolts a little to get the spacer on.
4. Put your wheel on. Your wheel must fit flat against the spacer. Some wheel rims may have a weld on the inner edge which will cause the wheel rim to sit on the edge of the spacer. In this case you will want to file some material off the edge of the spacer. This will allow the wheel rim to sit flat against the spacer to get proper compression. **Important: After you have installed your stud extenders, tighten your lug bolts as you would a car. Avoid hard tightening one side. This could crack the spacer. Tighten each bolt a little at a time (north, south, east & west) until recommended torque has been reached! (42 to 47 ft./lbs. ).** Ride your ATV and re-check lug bolts for tightness!

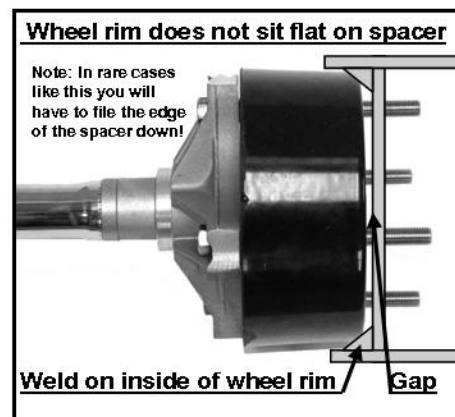
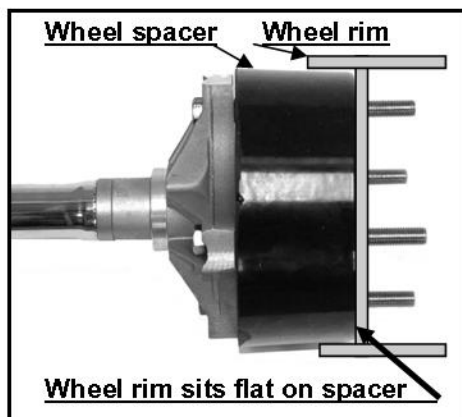
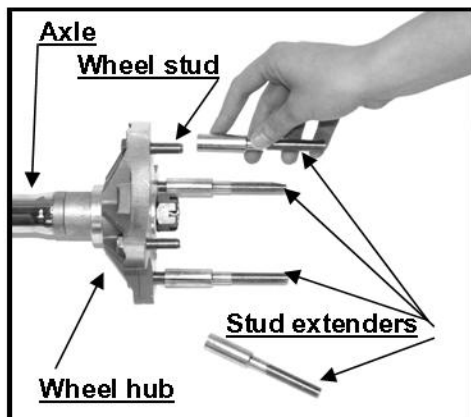

**Things to look for:** On quads like the Grizzly that use extra long lug bolts, the stud extenders may not screw all the way down to the wheel hub. This is okay. Go ahead and put your spacer on. **Check and make sure that the non-threaded part of the stud extender is not sticking out past the wheel spacer.** If it is, then your lug nuts will feel tight but your wheel will still be loose causing the spacers to fail. If you use aftermarket acorn type lug nuts, make sure that your studs do not bottom out in the top of the acorn style lug nut. If they do, you can trim the end of the stud extenders so they fit correctly.

**Note: These spacers are extremely tough and will last many years with proper installation!**

DuraBlue Inc. 20521 Crescent Bay Drive Lake Forest Ca. 92630 949-770-5533 [www.durablue.com](http://www.durablue.com)